

pinza pneumatica ø16 angolare

angular pneumatic gripper ø16

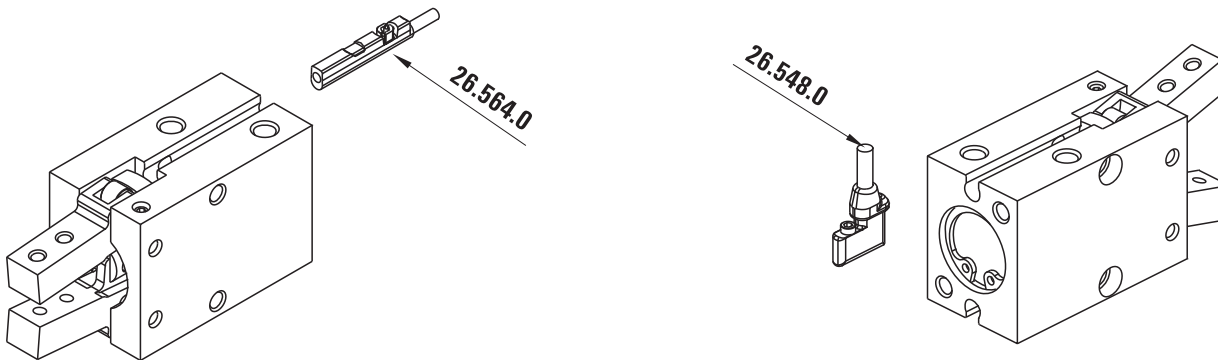
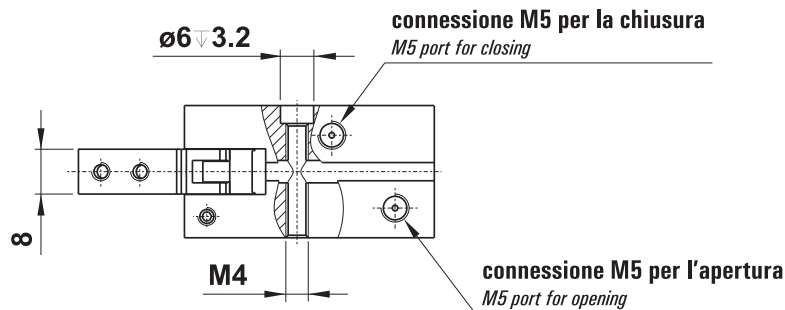
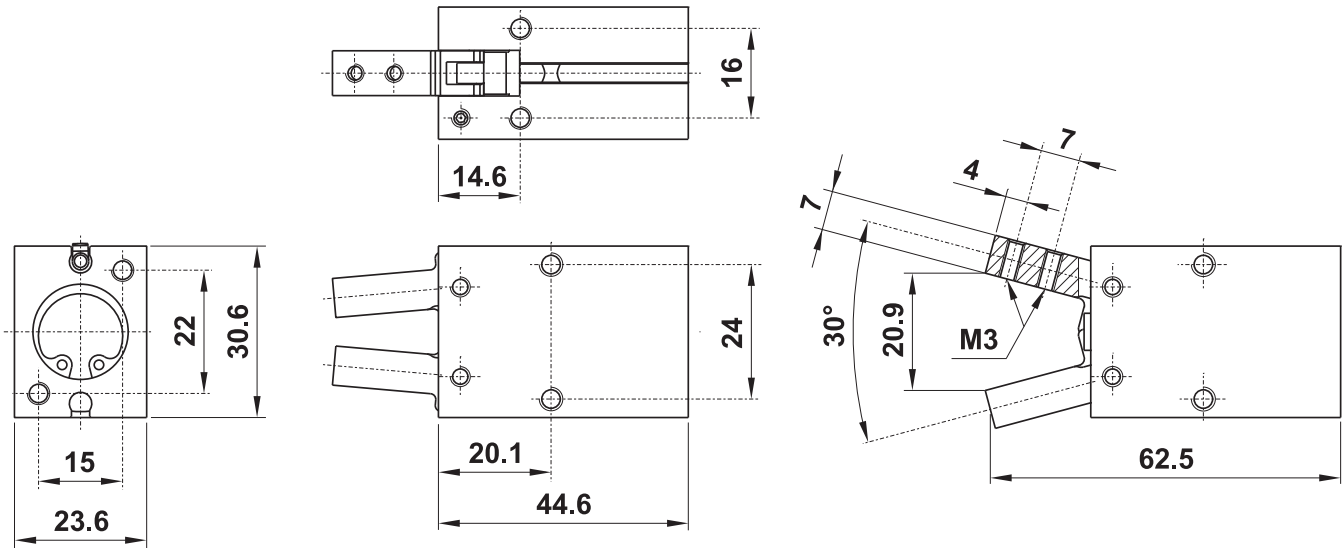

CODICE DI ORDINAZIONE ORDER CODE		34.320.4
Attacchi Ports		M5
Temperatura di esercizio Temperature range		-5 ... +70°C
Pressione di alimentazione Inlet pressure range		1 ... 7 bar 0.1 ... 0.7 MPa
Corsa totale di apertura Total opening stroke		-10° ... +30°
Massima frequenza di esercizio Maximum working frequency		190 cicli/min
Momento di spinta a 5 bar Gripping moment at 5 bar		0.4 Nm
Funzionamento Working system	Magnetico, doppio effetto Magnetic, double acting	
Fluido Fluid	Aria filtrata 50µ con o senza lubrificazione 50µ filtered, lubricated or non lubricated air	

Materiali

Corpo: alluminio anodizzato

Dita di presa: acciaio

Pistone: acciaio INOX AISI 304

Guarnizioni: poliuretano

Materials

Body: aluminium (anodize treatment)

Gripping fingers: steel

Piston: stainless steel AISI 304

Seals: polyurethane