

valvole a pedale

pedal valves



- Valvola a spola 5/2 - utilizzo come 3/2 o 2/2 tappando le altre connessioni
5/2 spool valve - it can be used as 3/2 or 2/2 by plugging the unused ports
- Attacchi filettati G1/4" sul corpo (raggruppati posteriormente)
G1/4" threaded ports
- Con o senza protezione
With or without protection cover
- Monostabile e bistabile
Mono-stable and bi-stable
- Versione con microvalvola e a portata progressiva
Version with microvalve and with progressive flow rate



Materiali

Corpo: alluminio 11S

Molle: INOX

Guarnizioni: NBR

Spola: alluminio nichelato

Parti interne: ottone OT58

Protezione: materiale plastico antiurto

Materials

Body: aluminium 11S

Springs: stainless steel

Seals: NBR

Spool: nickel plated aluminium

Internal parts: brass OT58

Protection cover: shock resistant plastic material

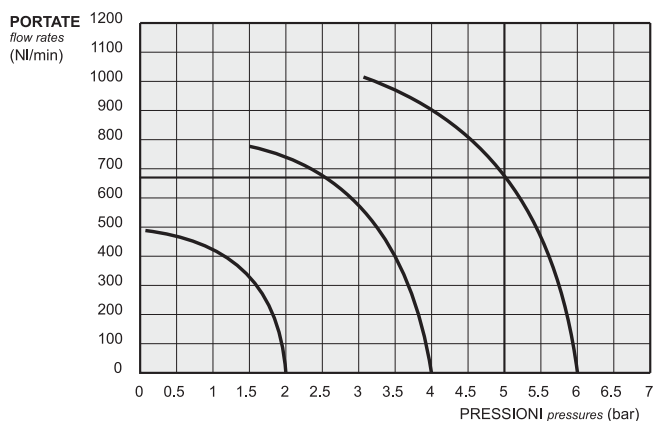

pedale elettrico electric pedal

Durata (cicli) <i>Life time (cycles)</i>	10.000.000
Resistenza contatto <i>Contact resistance</i>	25 mΩ
Grado di protezione elettrica <i>Electrical protection degree</i>	IP 54
Contatti <i>Contacts</i>	1 NA + 1 NC scatto rapido <i>1 NO + 1 NC rapid switch</i>

potenza di impiego secondo IEC 337-1 utilization power, according to IEC 337-1

DC		
V	24	220
A	6	0.1

AC				
V	24	220	380	500
A	10	10	8	6

Diametro nominale <i>Nominal orifice</i>	7.5 mm
Attacchi <i>Ports</i>	G1/4"
Temperatura di esercizio <i>Temperature range</i>	max +60°C
Pressione di esercizio <i>Working pressure</i>	2 ... 10 bar 0.2 ... 1 MPa
Fluido <i>Fluid</i>	Aria filtrata 50μ con o senza lubrificazione <i>50μ filtered, lubricated or non lubricated air</i>

pedali elettrici

electric pedals



PEDALE CON CONTATTO ELETTRICO NC-NA

pedal with electric contact NC-NO

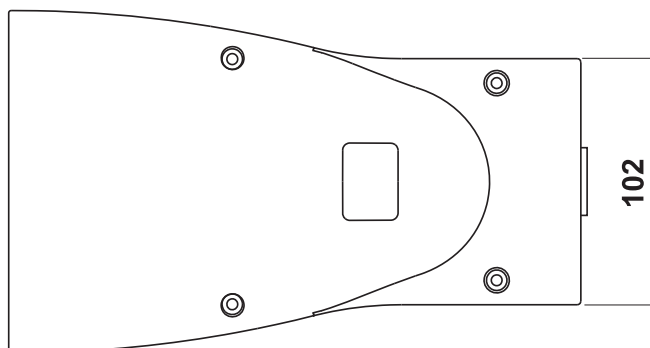
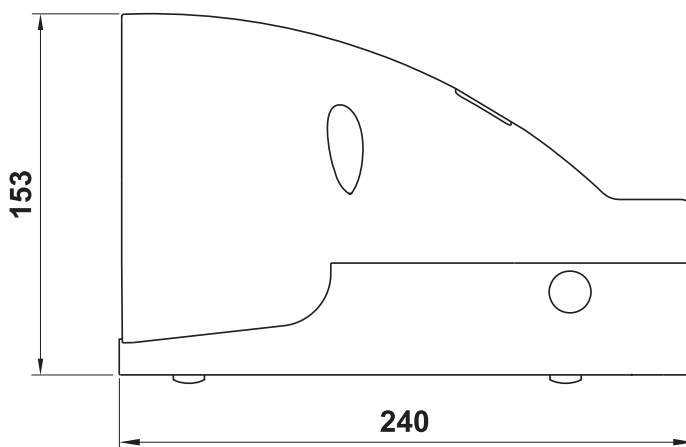
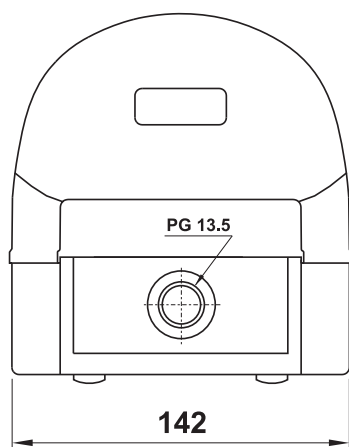

Colore della copertura: **GIALLO**

Cover colour: **YELLOW**

codice code	sigla part number	descrizione description	simbolo symbol
01.087.4N	PED EM	Pedale contatto elettrico NC-NA, monostabile con protezione <i>Mono-stable pedal with electric contact NC-NO, with protection cover</i>	
01.115.4N	PED EB	Pedale contatto elettrico NC-NA, bistabile con protezione <i>Bi-stable pedal with electric contact NC-NO, with protection cover</i>	
01.088.4N	PED ES	Pedale contatto elettrico NC-NA, monostabile con protezione e fermo di sicurezza* <i>Mono-stable pedal with electric contact NC-NO, with protection cover and safety feature*</i>	
01.127.4N	PED EBS	Pedale contatto elettrico NC-NA, bistabile con protezione e fermo di sicurezza* <i>Bi-stable pedal with electric contact NC-NO, with protection cover and safety feature*</i>	

* **Fermo di sicurezza:** è necessario premere il pedale a fondo con l'intera superficie della scarpa, onde evitare azionamenti accidentali.

* **Safety feature:** to avoid accidental operation the pedal must be fully depressed. Press on the pedal with the whole shoe surface.

pedali elettrici

electric pedals



PEDALE CON CONTATTO ELETTRICO NC-NA senza protezione

pedal with electric contact NC-NO - without protection cover

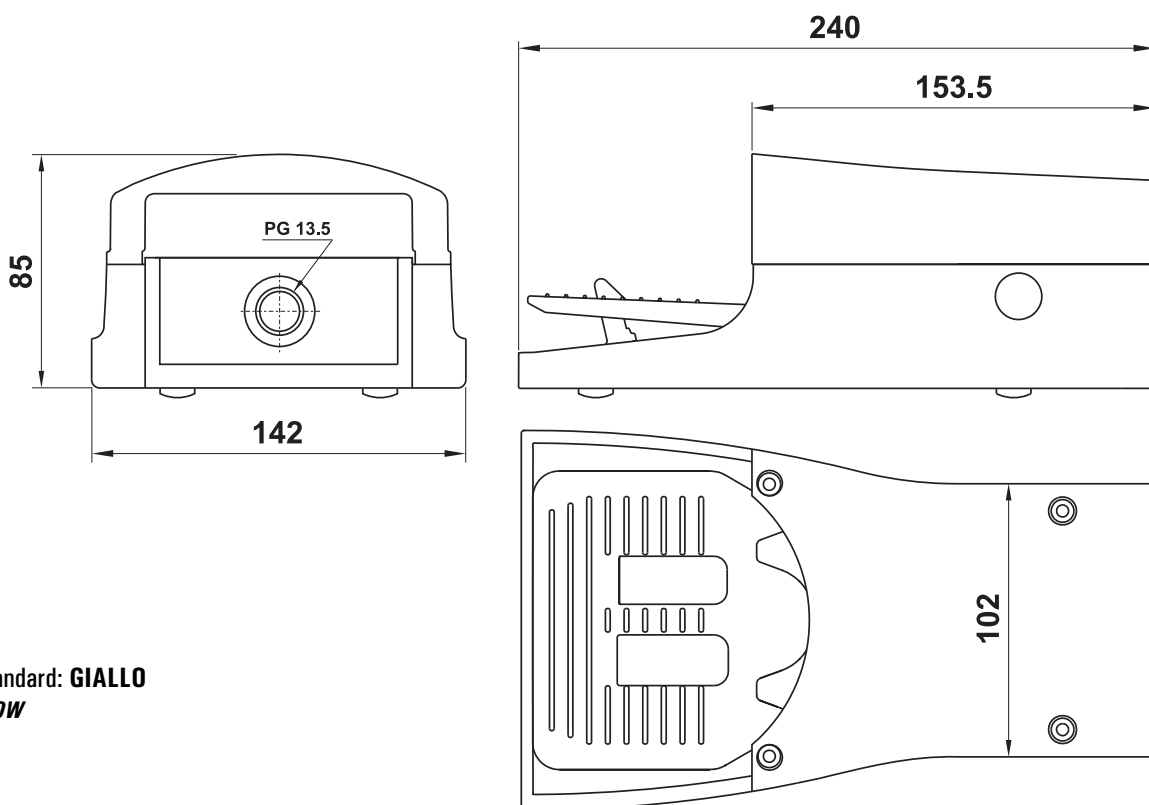

Colore della copertura standard: **GIALLO**

Standard cover colour: **YELLOW**

codice code	sigla part number	descrizione description		simbolo symbol
01.143.4N	PEDS EM	Pedale contatto elettrico NC-NA, monostabile senza protezione <i>Mono-stable pedal with electric contact NC-NO, without protection cover</i>		
01.144.4N	PEDS EB	giallo - yellow	Pedale contatto elettrico NC-NA, bistabile senza protezione <i>Bi-stable pedal with electric contact NC-NO, without protection cover</i>	
01.161.4N	PEDS EBR	rosso - red		
01.145.4N	PEDS ES	Pedale contatto elettr. NC-NA, monost. senza protezione, con fermo di sicurezza* <i>Mono-stable pedal with electric contact NC-NO, without protection cover, with safety feature*</i>		
01.146.4N	PEDS EBS	Pedale contatto elettr. NC-NA, bistabile senza protezione, con fermo di sicurezza* <i>Bi-stable pedal with electric contact NC-NO, without protection cover, with safety feature*</i>		

* **Fermo di sicurezza:** è necessario premere il pedale a fondo con l'intera superficie della scarpa, onde evitare azionamenti accidentali.

* **Safety feature:** to avoid accidental operation the pedal must be fully depressed. Press on the pedal with the whole shoe surface.

pedali elettrici

electric pedals



PEDALE CON DOPPIO CONTATTO ELETTRICO NC-NA

pedal with double electric contact NC-NO

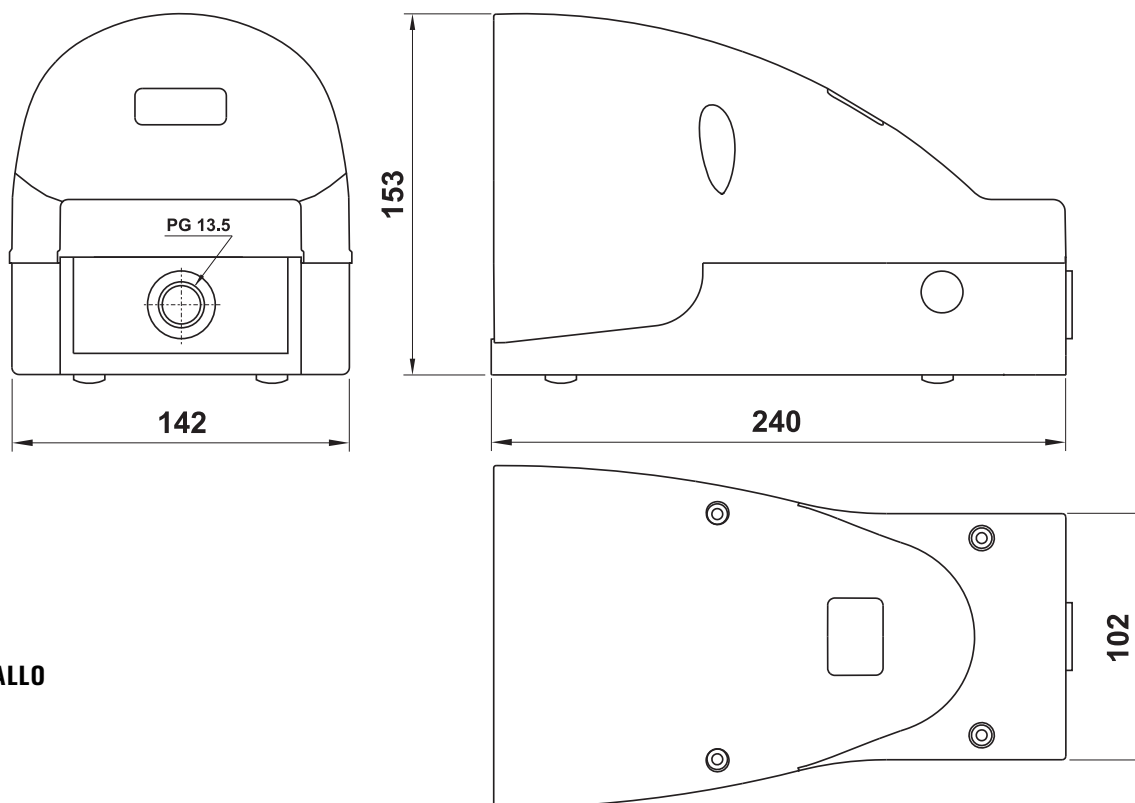
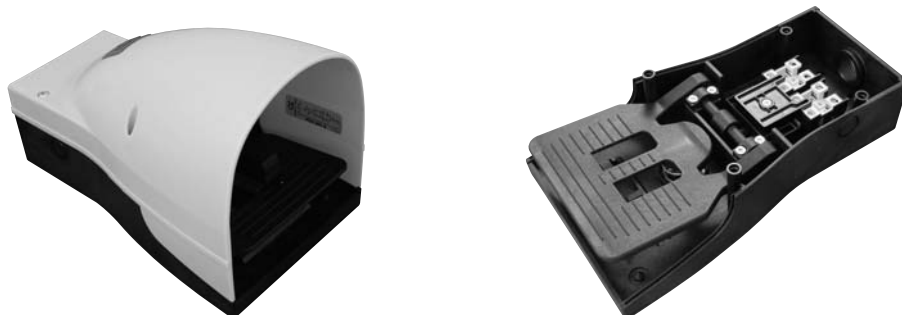

Colore della copertura: **GIALLO**

Cover colour: **YELLOW**

codice code	sigla part number	descrizione description	simbolo symbol
01.148.4N	PED EEM	Pedale doppio contatto elettrico NC-NA, monostabile con protezione <i>Mono-stable pedal with double electric contact NC-NO, with protection cover</i>	
01.149.4N	PED EEB	Pedale doppio contatto elettrico NC-NA, bistabile con protezione <i>Bi-stable pedal with double electric contact NC-NO, with protection cover</i>	
01.150.4N	PED EES	Pedale doppio cont. elettr. NC-NA, monostabile con protez. e fermo di sicurezza* <i>Mono-stable pedal with double electric contact NC-NO, with protection cover and safety feature*</i>	
01.151.4N	PED EEBS	Pedale doppio cont. elettr. NC-NA, bistabile con protezione e fermo di sicurezza* <i>Bi-stable pedal with double electric contact NC-NO, with protection cover and safety feature*</i>	

* **Fermo di sicurezza:** è necessario premere il pedale a fondo con l'intera superficie della scarpa, onde evitare azionamenti accidentali.

* **Safety feature:** to avoid accidental operation the pedal must be fully depressed. Press on the pedal with the whole shoe surface.

pedali elettrici

electric pedals



PEDALE CON DOPPIO CONTATTO ELETTRICO NC-NA senza protezione

pedal with double electric contact NC-NO - without protection cover

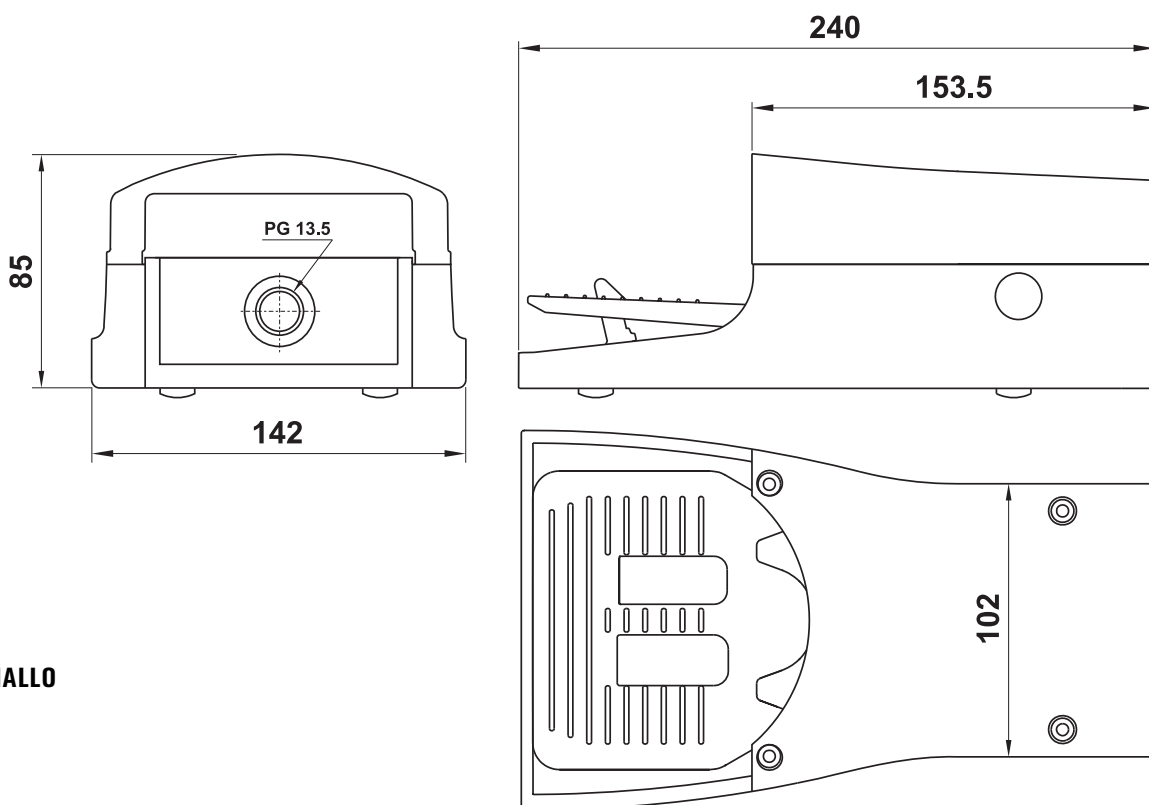

Colore della copertura: **GIALLO**

Cover colour: **YELLOW**

codice code	sigla part number	descrizione description	simbolo symbol
01.152.4N	PEDS EEM	Pedale doppio contatto elettrico NC-NA, monostabile senza protezione <i>Mono-stable pedal with double electric contact NC-NO, without protection cover</i>	
01.153.4N	PEDS EEB	Pedale doppio contatto elettrico NC-NA, bistabile senza protezione <i>Bi-stable pedal with double electric contact NC-NO, without protection cover</i>	
01.154.4N	PEDS EES	Pedale doppio cont. elettr. NC-NA, monost. senza protez., con fermo di sicurezza* <i>Mono-stable pedal with double electric contact NC-NO, without protection cover, with safety feature*</i>	
01.155.4N	PEDS EEBS	Pedale doppio cont. elettr. NC-NA, bist. senza protezione, con fermo di sicurezza* <i>Bi-stable pedal with double electric contact NC-NO, without protection cover, with safety feature*</i>	

* **Fermo di sicurezza:** è necessario premere il pedale a fondo con l'intera superficie della scarpa, onde evitare azionamenti accidentali.

* **Safety feature:** to avoid accidental operation the pedal must be fully depressed. Press on the pedal with the whole shoe surface.

pedali elettrici

electric pedals



MINIPEDALE ELETTRICO

electric mini-pedal

pedale elettrico con cavo 2 m
electric pedal with cable 2 m

CODICE DI ORDINAZIONE
ORDER CODE

01.158.4



Involucro: materiale plastico antiurto

Pedal body: shock resistant plastic material

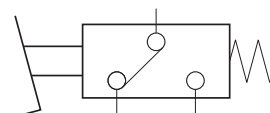
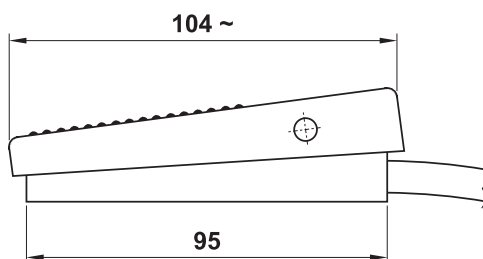
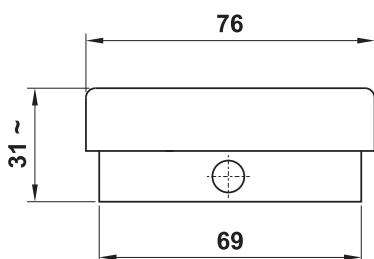

pedale elettrico senza cavo

electric pedal without cable

CODICE DI ORDINAZIONE
ORDER CODE

01.159.4

Involucro: materiale plastico antiurto

Pedal body: shock resistant plastic material

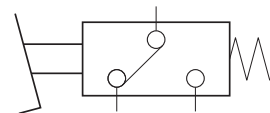

Durata (cicli) <i>Life time (cycles)</i>	5.000.000
Corrente di lavoro <i>Rating</i>	2 A 24 V ~ 6(3) A 250 V ~
Grado di protezione elettrica <i>Electrical protection degree</i>	IP 43
Forza di azionamento <i>Actuating force</i>	20 N

valvole a pedale

pedal valves



MINIPEDALE PNEUMATICO

mini-pedal pneumatic valve

pedale monostabile con microvalvola 3/2 NC

mono-stable pedal with microvalve 3/2 NC

CODICE DI ORDINAZIONE
ORDER CODE

PED 304 M

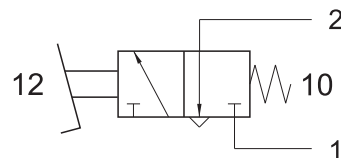

Involucro: materiale plastico antiurto

Pedal body: shock resistant plastic material

Attacchi Ports	automatici per tubo ø4 ø4 push-in
Portata nominale a 6 bar Nominal flow rate at 6 bar	100 NI/min

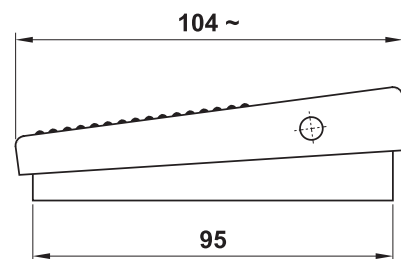
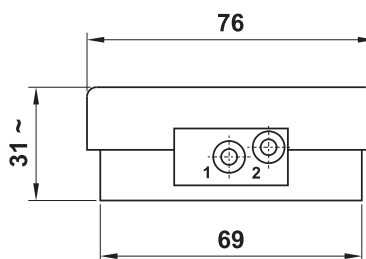

CODICE DI ORDINAZIONE
ORDER CODE

PED 305 M

Attacchi Ports	filettati M5 M5 threaded ports
Portata nominale a 6 bar Nominal flow rate at 6 bar	100 NI/min

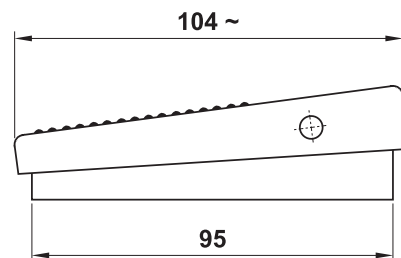
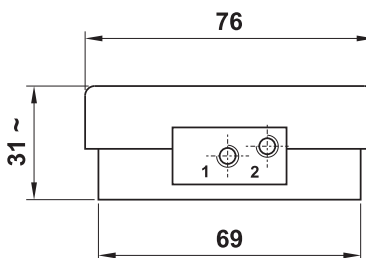

pedale monostabile con microvalvola 3/2 NA

mono-stable pedal with microvalve 3/2 NO

CODICE DI ORDINAZIONE
ORDER CODE

PED 314 M

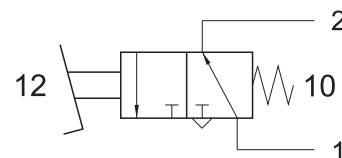

Involucro: materiale plastico antiurto

Pedal body: shock resistant plastic material

Attacchi Ports	automatici per tubo ø4 ø4 push-in
Portata nominale a 6 bar Nominal flow rate at 6 bar	100 NI/min

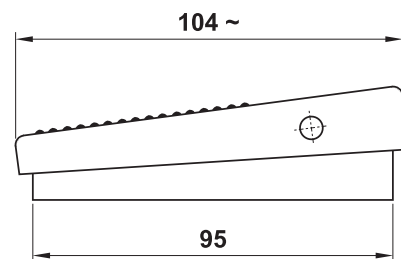
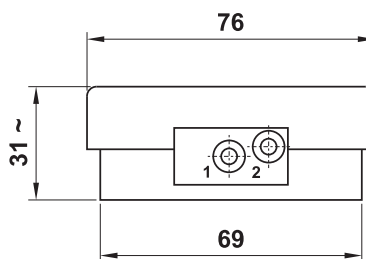

valvole a pedale

pedal valves



PEDALE CON VALVOLA A SPOLA 5/2 G1/4" SERVOPILOTATA

pedal with 5/2 G1/4" servo-piloted spool valve

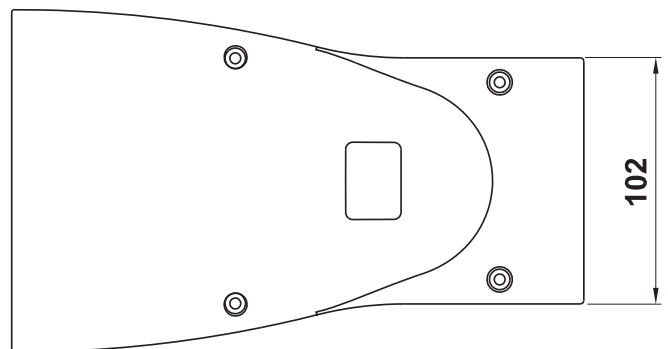
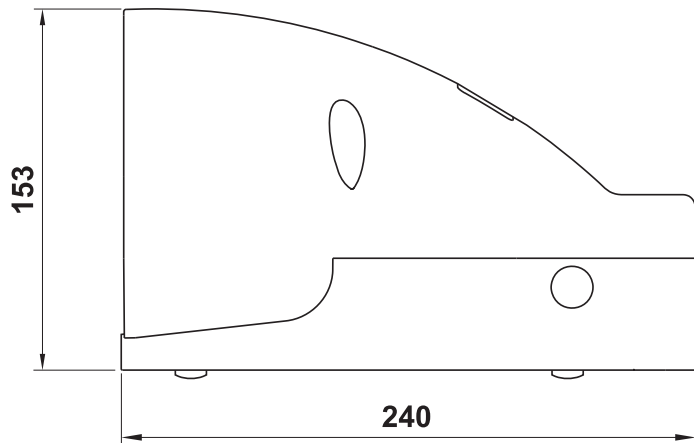
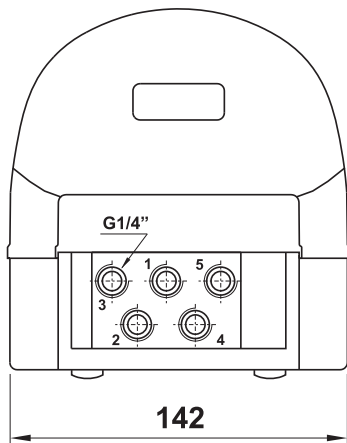

Colore della copertura: **GIALLO**

Cover colour: **YELLOW**

codice code	sigla part number	descrizione description	simbolo symbol
01.052.4N	PED 502 M	Pedale 5/2 1/4" monostabile con protezione <i>Mono-stable pedal valve 5/2 1/4" with protection cover</i>	
01.053.4N	PED 502 B	Pedale 5/2 1/4" bistabile con protezione <i>Bi-stable pedal valve 5/2 1/4" with protection cover</i>	
01.072.4N	PED 502 S	Pedale 5/2 1/4" monostabile con protezione e fermo di sicurezza* <i>Mono-stable pedal valve 5/2 1/4" with protection cover and safety feature*</i>	
01.126.4N	PED 502 BS	Pedale 5/2 1/4" bistabile con protezione e fermo di sicurezza* <i>Bi-stable pedal valve 5/2 1/4" with protection cover and safety feature*</i>	

* **Fermo di sicurezza:** è necessario premere il pedale a fondo con l'intera superficie della scarpa, onde evitare azionamenti accidentali.

* **Safety feature:** to avoid accidental operation the pedal must be fully depressed. Press on the pedal with the whole shoe surface.

Ricambi - spare parts

01.051.3 : valvola 5/2 G1/4" per pedale [5/2 G1/4" valve for pedal]

01.023.2 : kit guarnizioni per valvola pedale 5/2 [seals kit for 5/2 pedal valve]

valvole a pedale

pedal valves



PEDALE CON VALVOLA A SPOLA 5/2 G1/4" SERVOPILOTATA - senza protezione

pedal with 5/2 G1/4" servo-piloted spool valve - without protection cover

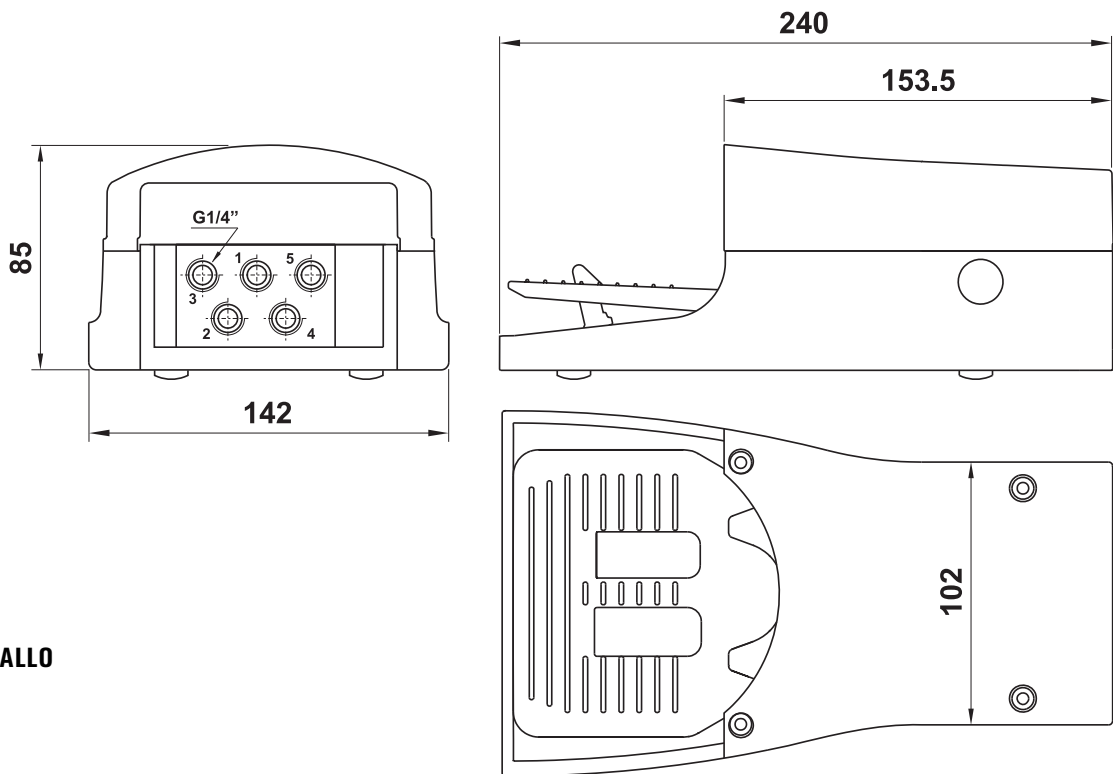

Colore della copertura: **GIALLO**

Cover colour: **YELLOW**

codice code	sigla part number	descrizione description	simbolo symbol
01.080.4N	PEDS 502 M	Pedale 5/2 1/4" monostabile senza protezione <i>Mono-stable pedal valve 5/2 1/4" without protection cover</i>	
01.081.4N	PEDS 502 B	Pedale 5/2 1/4" bistabile senza protezione <i>Bi-stable pedal valve 5/2 1/4" without protection cover</i>	
01.128.4N	PEDS 502 S	Pedale 5/2 1/4" monostabile senza protezione, con fermo di sicurezza* <i>Mono-stable pedal valve 5/2 1/4" without protection cover, with safety feature*</i>	
01.129.4N	PEDS 502 BS	Pedale 5/2 1/4" bistabile senza protezione, con fermo di sicurezza* <i>Bi-stable pedal valve 5/2 1/4" without protection cover, with safety feature*</i>	

* **Fermo di sicurezza:** è necessario premere il pedale a fondo con l'intera superficie della scarpa, onde evitare azionamenti accidentali.

* **Safety feature:** to avoid accidental operation the pedal must be fully depressed. Press on the pedal with the whole shoe surface.

Ricambi - spare parts

01.051.3 : valvola 5/2 G1/4" per pedale [5/2 G1/4" valve for pedal]

01.023.2 : kit guarnizioni per valvola pedale 5/2 [seals kit for 5/2 pedal valve]

valvole a pedale

pedal valves



PEDALE CON VALVOLA A SPOLA 5/2 G1/4" SERVOPILOTATA - valvola in posizione arretrata

pedal with 5/2 G1/4" servo-piloted spool valve - valve in rear position

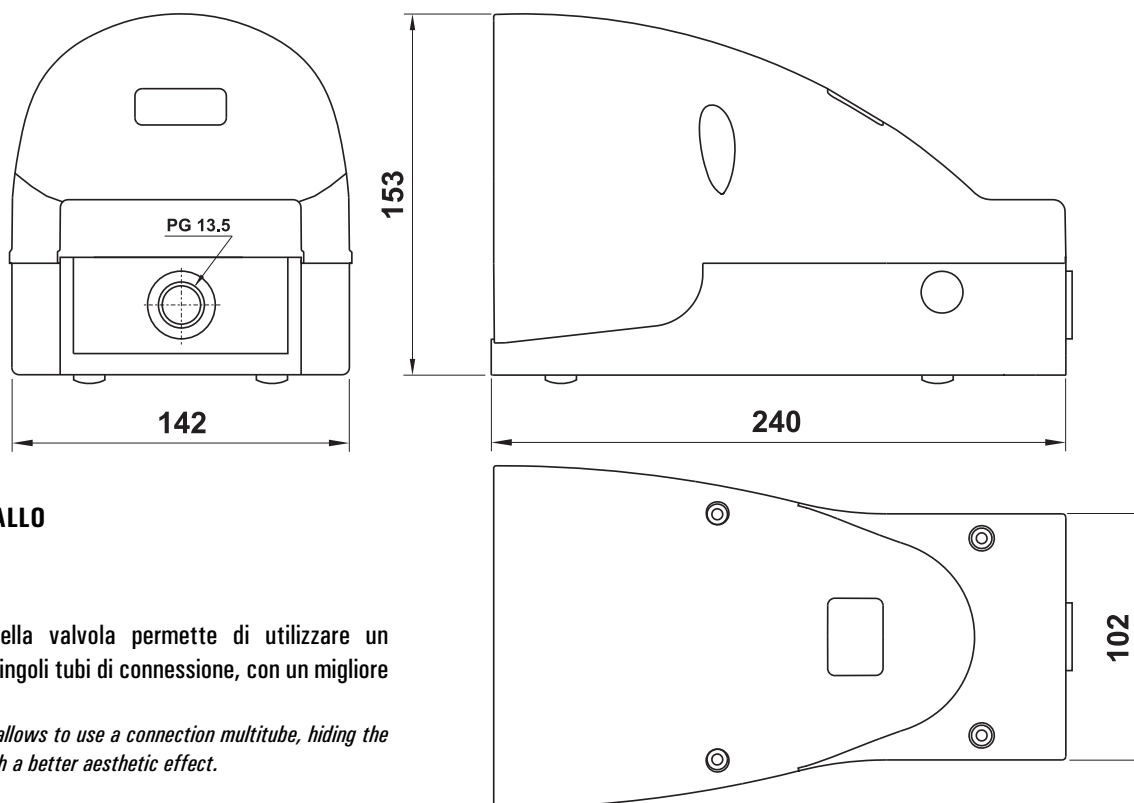
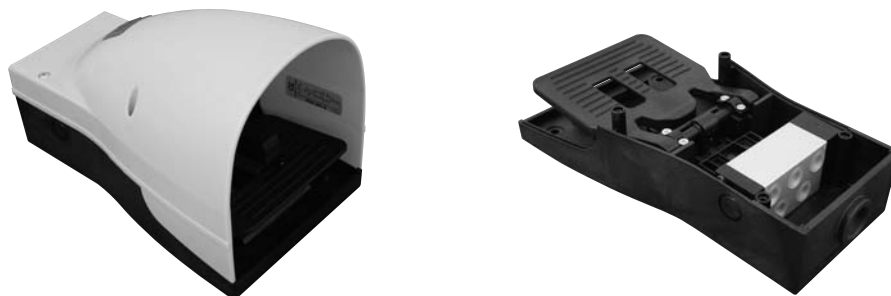

Colore della copertura: **GIALLO**

Cover colour: **YELLOW**

La posizione arretrata della valvola permette di utilizzare un multitubo che maschera i singoli tubi di connessione, con un migliore risultato estetico.

The rear position of the valve allows to use a connection multitube, hiding the single air connection tubes with a better aesthetic effect.

codice code	sigla part number	descrizione description	simbolo symbol
01.135.4N	PED 502 MA	Pedale 5/2 1/4" monostabile con protezione <i>Mono-stable pedal valve 5/2 1/4" with protection cover</i>	
01.136.4N	PED 502 BA	Pedale 5/2 1/4" bistabile con protezione <i>Bi-stable pedal valve 5/2 1/4" with protection cover</i>	
01.137.4N	PED 502 SA	Pedale 5/2 1/4" monostabile con protezione e fermo di sicurezza* <i>Mono-stable pedal valve 5/2 1/4" with protection cover and safety feature*</i>	
01.138.4N	PED 502 BSA	Pedale 5/2 1/4" bistabile con protezione e fermo di sicurezza* <i>Bi-stable pedal valve 5/2 1/4" with protection cover and safety feature*</i>	

* Fermo di sicurezza: è necessario premere il pedale a fondo con l'intera superficie della scarpa, onde evitare azionamenti accidentali.

* Safety feature: to avoid accidental operation the pedal must be fully depressed. Press on the pedal with the whole shoe surface.

Ricambi - spare parts

01.051.3 : valvola 5/2 G1/4" per pedale [5/2 G1/4" valve for pedal]

01.023.2 : kit guarnizioni per valvola pedale 5/2 [seals kit for 5/2 pedal valve]

valvole a pedale

pedal valves



PEDALE CON VALVOLA A SPOLA 5/2 G1/4" SERVOPILOTATA - valvola in posizione arretrata - senza protezione
pedal with 5/2 G1/4" servo-piloted spool valve - valve in rear position - without protection cover

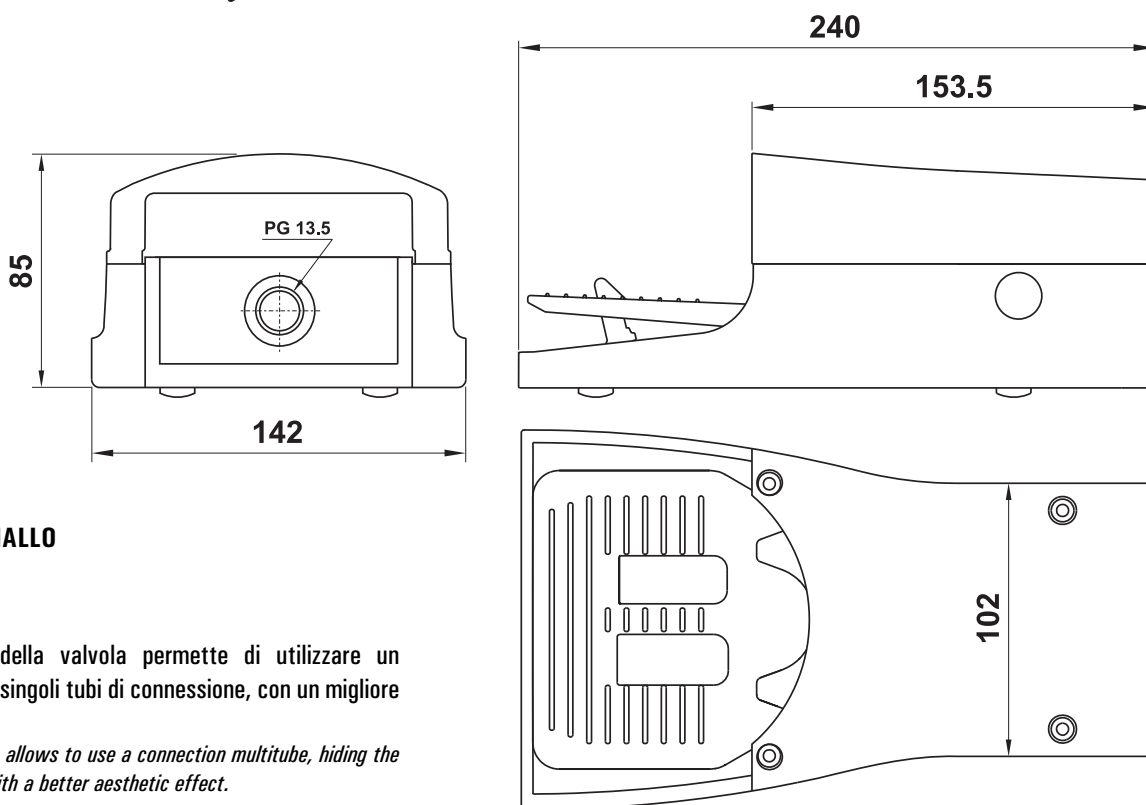

Colore della copertura: **GIALLO**

Cover colour: **YELLOW**

La posizione arretrata della valvola permette di utilizzare un multitubo che maschera i singoli tubi di connessione, con un migliore risultato estetico.

The rear position of the valve allows to use a connection multitube, hiding the single air connection tubes with a better aesthetic effect.

codice code	sigla part number	descrizione description	simbolo symbol
01.139.4N	PEDS 502 MA	Pedale 5/2 1/4" monostabile senza protezione <i>Mono-stable pedal valve 5/2 1/4" without protection cover</i>	
01.140.4N	PEDS 502 BA	Pedale 5/2 1/4" bistabile senza protezione <i>Bi-stable pedal valve 5/2 1/4" without protection cover</i>	
01.141.4N	PEDS 502 SA	Pedale 5/2 1/4" monostabile senza protezione, con fermo di sicurezza* <i>Mono-stable pedal valve 5/2 1/4" without protection cover, with safety feature*</i>	
01.142.4N	PEDS 502 BSA	Pedale 5/2 1/4" bistabile senza protezione, con fermo di sicurezza* <i>Bi-stable pedal valve 5/2 1/4" without protection cover, with safety feature*</i>	

* **Fermo di sicurezza:** è necessario premere il pedale a fondo con l'intera superficie della scarpa, onde evitare azionamenti accidentali.

* **Safety feature:** to avoid accidental operation the pedal must be fully depressed. Press on the pedal with the whole shoe surface.

Ricambi - spare parts

01.051.3 : valvola 5/2 G1/4" per pedale [5/2 G1/4" valve for pedal]

01.023.2 : kit guarnizioni per valvola pedale 5/2 [seals kit for 5/2 pedal valve]

valvole a pedale

pedal valves



PEDALE CON MICROVALVOLA 3/2 NC, raccordi automatici tubo ø4

pedal with 3/2 NC microvalve, push-in fittings for ø4 tube

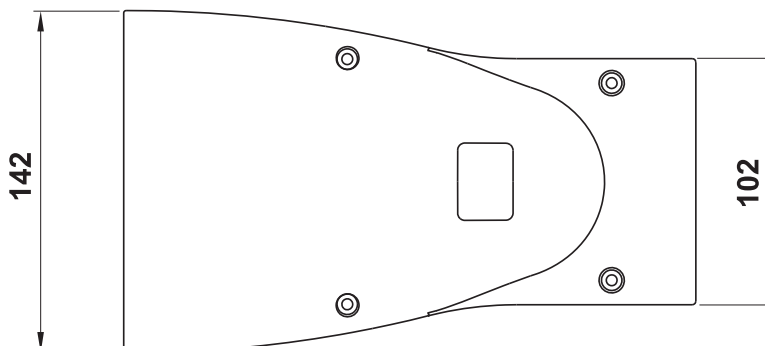
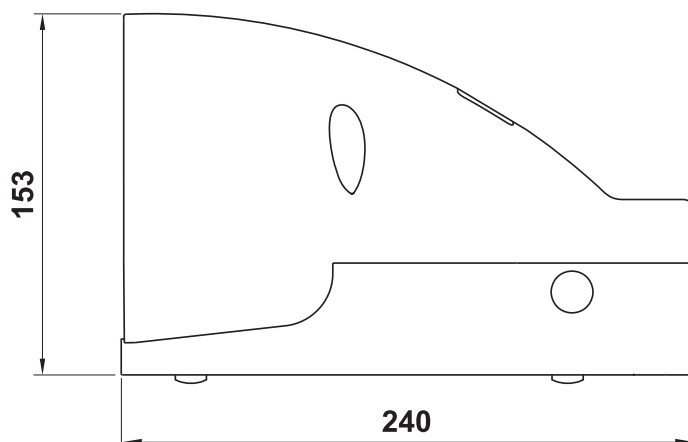
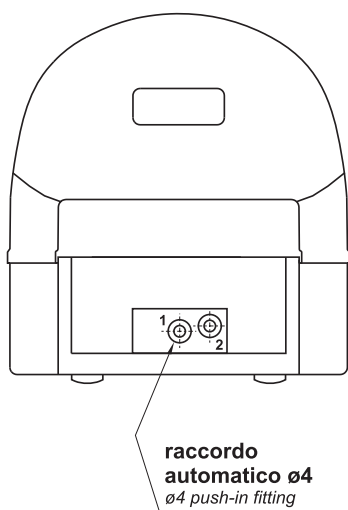

Colore della copertura: **GIALLO**

Cover colour: **YELLOW**

codice code	sigla part number	descrizione description	simbolo symbol
08.197.4N	PEDN 304 M	Pedale 3/2 NC tubo ø4 - monostabile con protezione <i>Mono-stable pedal valve 3/2 NC, push-in fittings ø4, with protection cover</i>	
08.198.4N	PEDN 304 B	Pedale 3/2 NC tubo ø4 - bistabile con protezione <i>Bi-stable pedal valve 3/2 NC, push-in fittings ø4, with protection cover</i>	
08.207.4N	PEDN 304 S	Pedale 3/2 NC tubo ø4 - monostabile con protezione e fermo di sicurezza* <i>Mono-stable pedal valve 3/2 NC, push-in fittings ø4, with protection cover and safety feature*</i>	
08.209.4N	PEDN 304 BS	Pedale 3/2 NC tubo ø4 - bistabile con protezione e fermo di sicurezza* <i>Bi-stable pedal valve 3/2 NC, push-in fittings ø4, with protection cover and safety feature*</i>	

* **Fermo di sicurezza:** è necessario premere il pedale a fondo con l'intera superficie della scarpa, onde evitare azionamenti accidentali.

* **Safety feature:** to avoid accidental operation the pedal must be fully depressed. Press on the pedal with the whole shoe surface.

valvole a pedale

pedal valves



PEDALE CON MICROVALVOLA 3/2 NC, raccordi automatici tubo $\varnothing 4$ - senza protezione
pedal with 3/2 NC microvalve, push-in fittings for $\varnothing 4$ tube - without protection cover

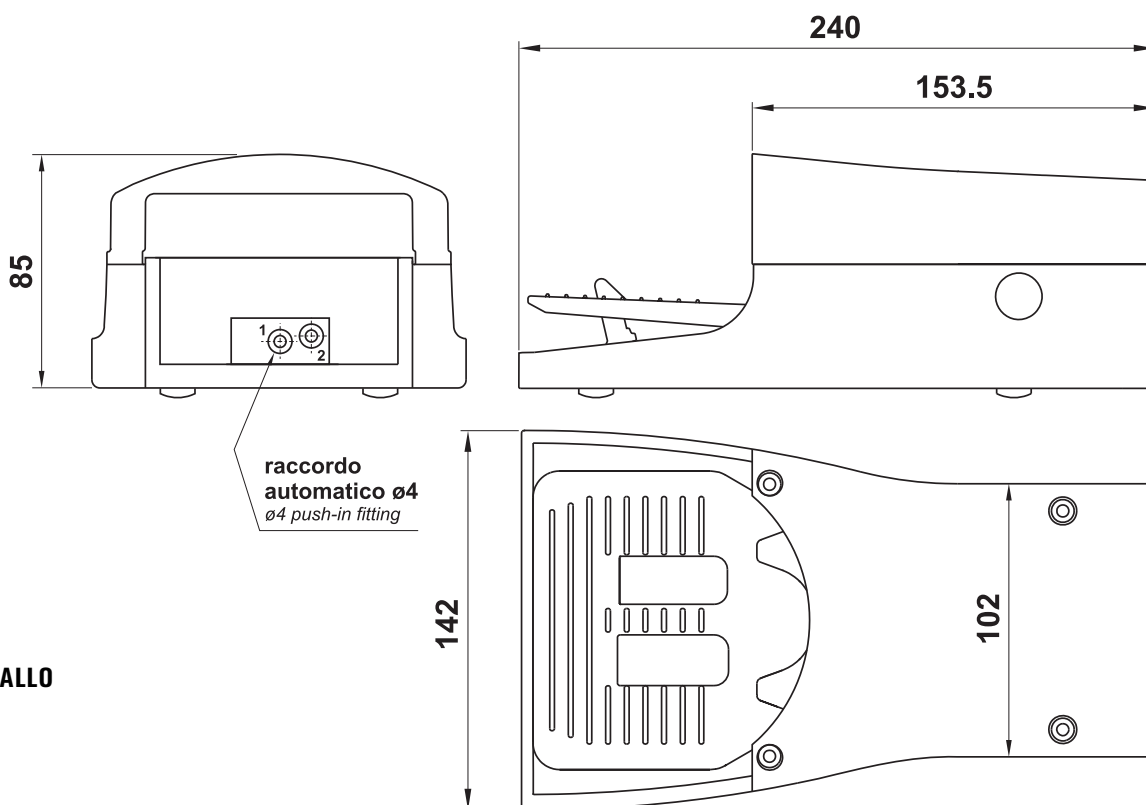

Colore della copertura: **GIALLO**
 Cover colour: **YELLOW**

codice code	sigla part number	descrizione description	simbolo symbol
08.307.4N	PEDS 304 M	Pedale 3/2 NC tubo $\varnothing 4$ - monostabile senza protezione <i>Mono-stable pedal valve 3/2 NC, push-in fittings $\varnothing 4$, without protection cover</i>	
08.308.4N	PEDS 304 B	Pedale 3/2 NC tubo $\varnothing 4$ - bistabile senza protezione <i>Bi-stable pedal valve 3/2 NC, push-in fittings $\varnothing 4$, without protection cover</i>	
08.309.4N	PEDS 304 S	Pedale 3/2 NC tubo $\varnothing 4$ - monost. senza protezione, con fermo di sicurezza* <i>Mono-stable pedal valve 3/2 NC, push-in fittings $\varnothing 4$, without protection cover, with safety feature*</i>	
08.310.4N	PEDS 304 BS	Pedale 3/2 NC tubo $\varnothing 4$ - bistabile senza protezione, con fermo di sicurezza* <i>Bi-stable pedal valve 3/2 NC, push-in fittings $\varnothing 4$, without protection cover, with safety feature*</i>	

* **Fermo di sicurezza:** è necessario premere il pedale a fondo con l'intera superficie della scarpa, onde evitare azionamenti accidentali.

* **Safety feature:** to avoid accidental operation the pedal must be fully depressed. Press on the pedal with the whole shoe surface.

valvole a pedale

pedal valves



PEDALE CON MICROVALVOLA 3/2 NC, raccordi automatici tubo $\varnothing 4$ - valvola in posizione arretrata
pedal with 3/2 NC microvalve, push-in fittings for $\varnothing 4$ tube - valve in rear position

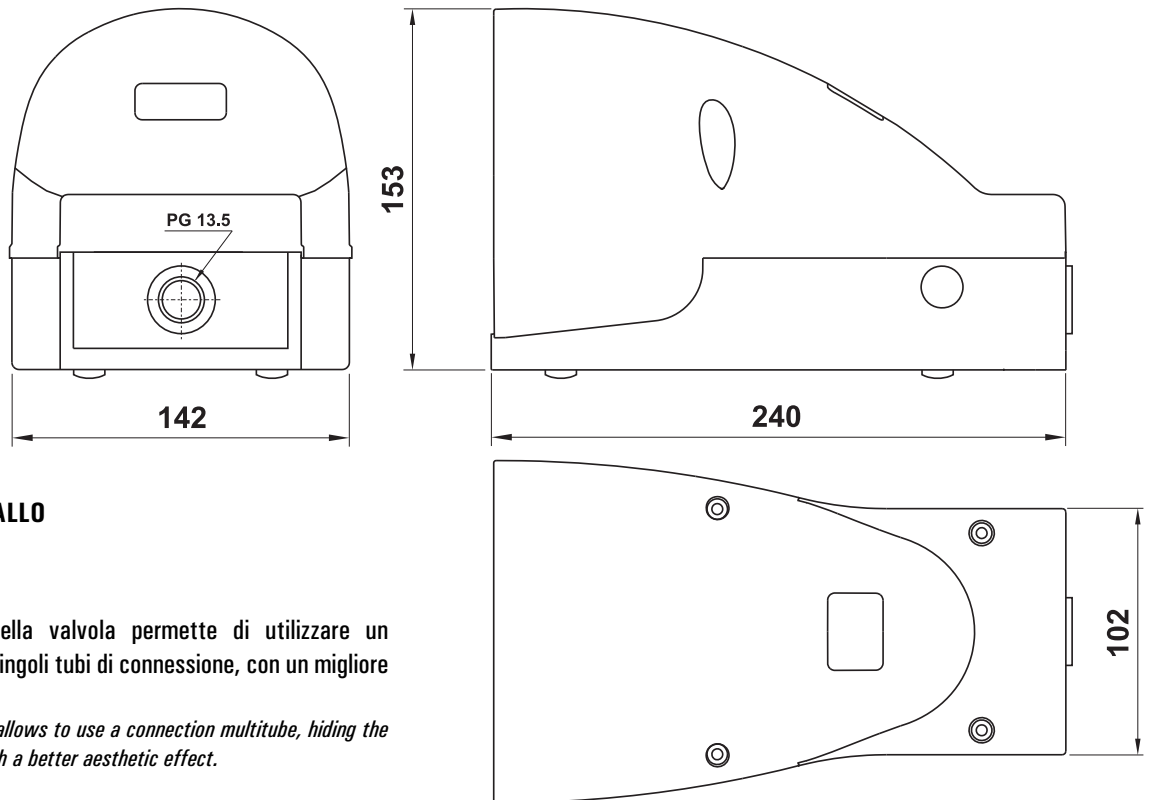

Colore della copertura: **GIALLO**
 Cover colour: **YELLOW**

La posizione arretrata della valvola permette di utilizzare un multitubo che maschera i singoli tubi di connessione, con un migliore risultato estetico.

The rear position of the valve allows to use a connection multitube, hiding the single air connection tubes with a better aesthetic effect.

codice code	sigla part number	descrizione description	simbolo symbol
08.311.4N	PEDN 304 MA	Pedale 3/2 NC tubo $\varnothing 4$ - monostabile con protezione <i>Mono-stable pedal valve 3/2 NC, push-in fittings $\varnothing 4$, with protection cover</i>	
08.312.4N	PEDN 304 BA	Pedale 3/2 NC tubo $\varnothing 4$ - bistabile con protezione <i>Bi-stable pedal valve 3/2 NC, push-in fittings $\varnothing 4$, with protection cover</i>	
08.313.4N	PEDN 304 SA	Pedale 3/2 NC tubo $\varnothing 4$ - monostabile con protezione e fermo di sicurezza* <i>Mono-stable pedal valve 3/2 NC, push-in fittings $\varnothing 4$, with protection cover and safety feature*</i>	
08.314.4N	PEDN 304 BSA	Pedale 3/2 NC tubo $\varnothing 4$ - bistabile con protezione e fermo di sicurezza* <i>Bi-stable pedal valve 3/2 NC, push-in fittings $\varnothing 4$, with protection cover and safety feature*</i>	

* **Fermo di sicurezza:** è necessario premere il pedale a fondo con l'intera superficie della scarpa, onde evitare azionamenti accidentali.

* **Safety feature:** to avoid accidental operation the pedal must be fully depressed. Press on the pedal with the whole shoe surface.

valvole a pedale

pedal valves



PEDALE CON MICROVALVOLA 3/2 NC, racc. autom. ø4 - valvola in posizione arretrata - senza protezione
pedal with 3/2 NC microvalve, push-in fittings for ø4 tube - valve in rear position - without protection cover

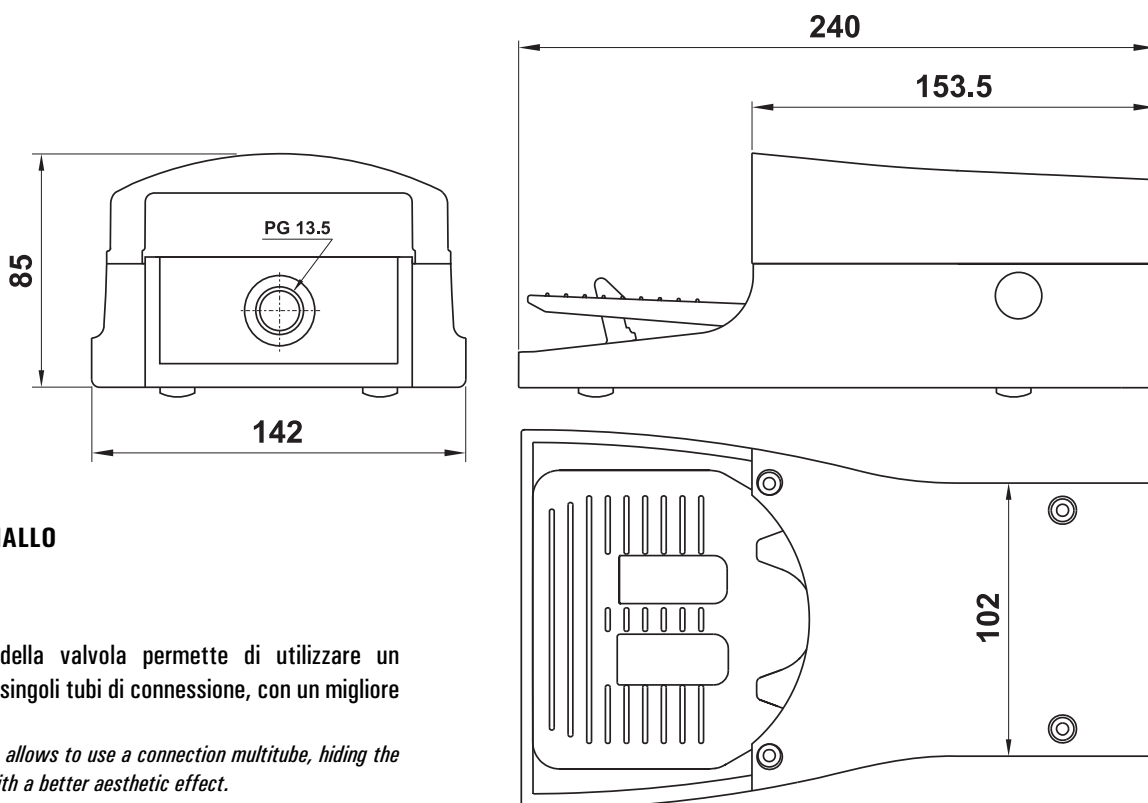

Colore della copertura: **GIALLO**
 Cover colour: **YELLOW**

La posizione arretrata della valvola permette di utilizzare un multitubo che maschera i singoli tubi di connessione, con un migliore risultato estetico.
 The rear position of the valve allows to use a connection multitube, hiding the single air connection tubes with a better aesthetic effect.

codice code	sigla part number	descrizione description	simbolo symbol
08.315.4N	PEDS 304 MA	Pedale 3/2 NC tubo ø4 - monostabile senza protezione <i>Mono-stable pedal valve 3/2 NC, push-in fittings ø4, without protection cover</i>	
08.316.4N	PEDS 304 BA	Pedale 3/2 NC tubo ø4 - bistabile senza protezione <i>Bi-stable pedal valve 3/2 NC, push-in fittings ø4, without protection cover</i>	
08.317.4N	PEDS 304 SA	Pedale 3/2 NC tubo ø4 - monost. senza protezione, con fermo di sicurezza* <i>Mono-stable pedal valve 3/2 NC, push-in fittings ø4, without protection cover, with safety feature*</i>	
08.318.4N	PEDS 304 BSA	Pedale 3/2 NC tubo ø4 - bistabile senza protezione, con fermo di sicurezza* <i>Bi-stable pedal valve 3/2 NC, push-in fittings ø4, without protection cover, with safety feature*</i>	

* **Fermo di sicurezza:** è necessario premere il pedale a fondo con l'intera superficie della scarpa, onde evitare azionamenti accidentali.
 * **Safety feature:** to avoid accidental operation the pedal must be fully depressed. Press on the pedal with the whole shoe surface.

valvole a pedale

pedal valves



PEDALE CON MICROVALVOLA 5/2, raccordi automatici tubo ø4

pedal with 5/2 microvalve, push-in fittings for ø4 tube

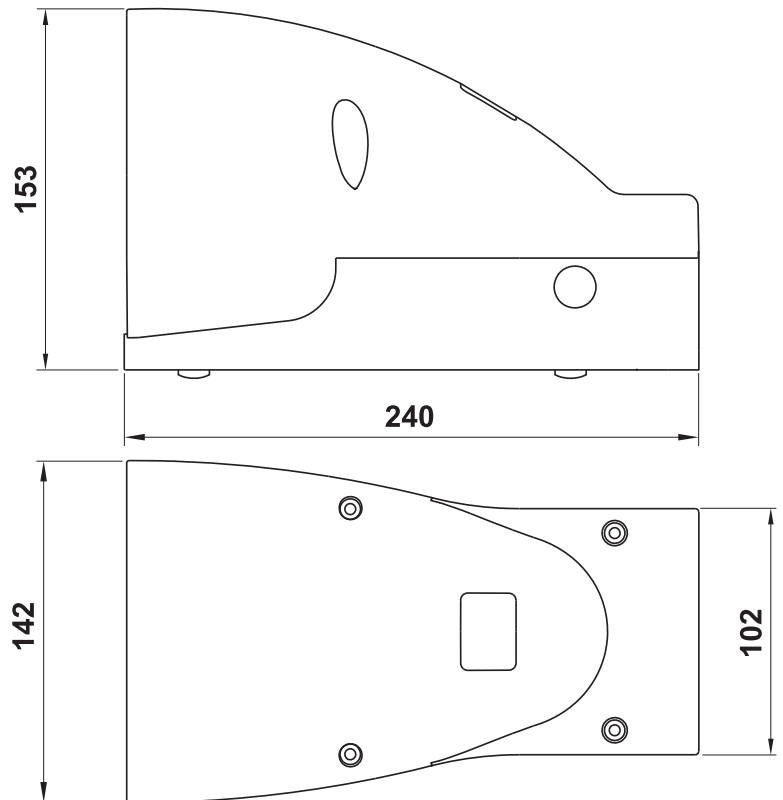
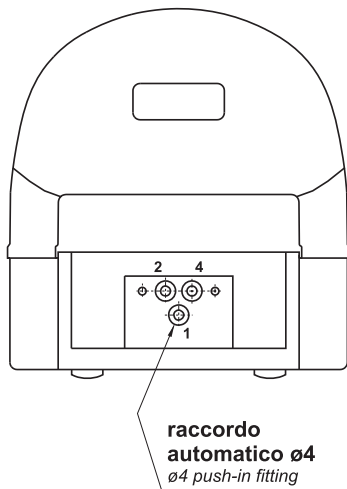

Colore della copertura: **GIALLO**
Cover colour: **YELLOW**

codice code	sigla part number	descrizione description	simbolo symbol
08.303.4N	PED 504 M	Pedale 5/2 tubo ø4 - monostabile con protezione <i>Mono-stable pedal valve 5/2, push-in fittings ø4, with protection cover</i>	
08.304.4N	PED 504 B	Pedale 5/2 tubo ø4 - bistabile con protezione <i>Bi-stable pedal valve 5/2, push-in fittings ø4, with protection cover</i>	
08.305.4N	PED 504 S	Pedale 5/2 tubo ø4 - monostabile con protezione e fermo di sicurezza* <i>Mono-stable pedal valve 5/2, push-in fittings ø4, with protection cover and safety feature*</i>	
08.306.4N	PED 504 BS	Pedale 5/2 tubo ø4 - bistabile con protezione e fermo di sicurezza* <i>Bi-stable pedal valve 5/2, push-in fittings ø4, with protection cover and safety feature*</i>	

* **Fermo di sicurezza:** è necessario premere il pedale a fondo con l'intera superficie della scarpa, onde evitare azionamenti accidentali.

* **Safety feature:** to avoid accidental operation the pedal must be fully depressed. Press on the pedal with the whole shoe surface.

valvole a pedale

pedal valves



PEDALE CON MICROVALVOLA 5/2, raccordi automatici tubo ø4 - senza protezione
pedal with 5/2 microvalve, push-in fittings for ø4 tube - without protection cover

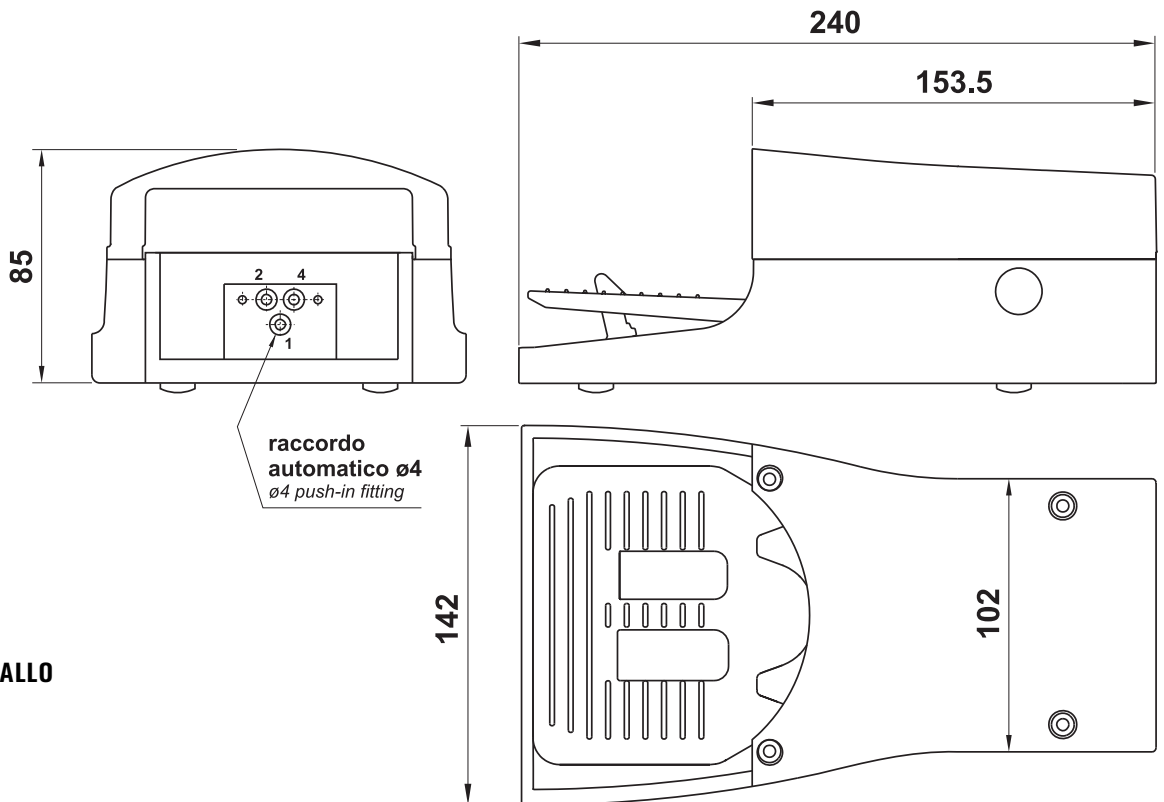

Colore della copertura: **GIALLO**
 Cover colour: **YELLOW**

codice code	sigla part number	descrizione description	simbolo symbol
08.319.4N	PEDS 504 M	Pedale 5/2 tubo ø4 - monostabile senza protezione <i>Mono-stable pedal valve 5/2, push-in fittings ø4, without protection cover</i>	
08.320.4N	PEDS 504 B	Pedale 5/2 tubo ø4 - bistabile senza protezione <i>Bi-stable pedal valve 5/2, push-in fittings ø4, without protection cover</i>	
08.321.4N	PEDS 504 S	Pedale 5/2 tubo ø4 - monostabile senza protezione, con fermo di sicurezza* <i>Mono-stable pedal valve 5/2, push-in fittings ø4, without protection cover, with safety feature*</i>	
08.322.4N	PEDS 504 BS	Pedale 5/2 tubo ø4 - bistabile senza protezione, con fermo di sicurezza* <i>Bi-stable pedal valve 5/2, push-in fittings ø4, without protection cover, with safety feature*</i>	

* **Fermo di sicurezza:** è necessario premere il pedale a fondo con l'intera superficie della scarpa, onde evitare azionamenti accidentali.

* **Safety feature:** to avoid accidental operation the pedal must be fully depressed. Press on the pedal with the whole shoe surface.

valvole a pedale

pedal valves



PEDALE CON MICROVALVOLA 5/2, raccordi automatici tubo ø4 - valvola in posizione arretrata
pedal with 5/2 microvalve, push-in fittings for ø4 tube - valve in rear position

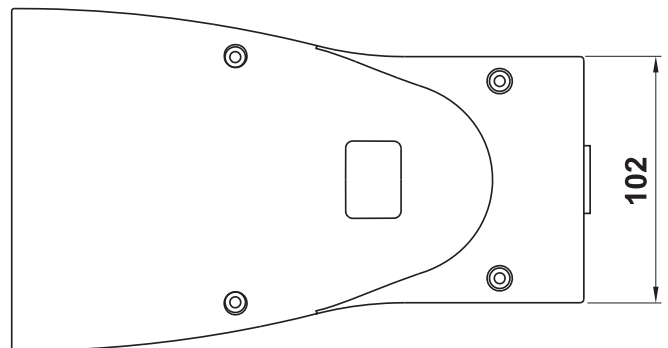
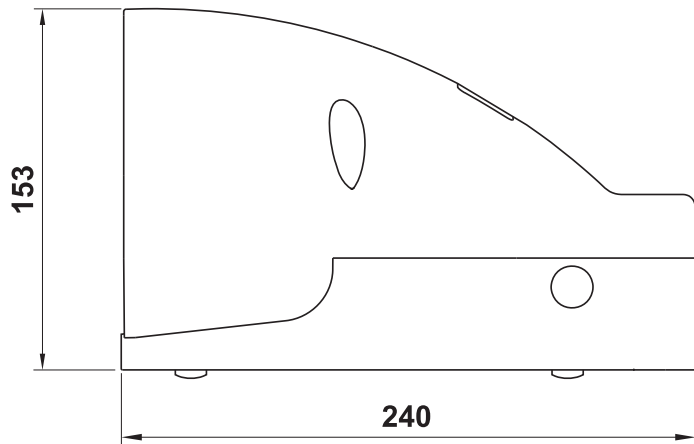
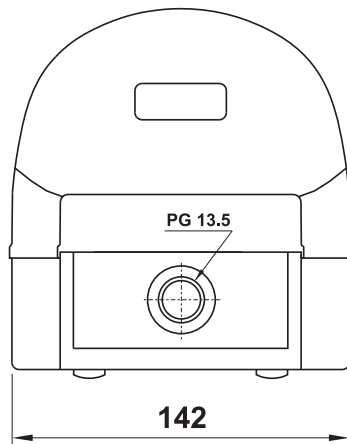

Colore della copertura: **GIALLO**
 Cover colour: **YELLOW**

La posizione arretrata della valvola permette di utilizzare un multitubo che maschera i singoli tubi di connessione, con un migliore risultato estetico.
 The rear position of the valve allows to use a connection multitube, hiding the single air connection tubes with a better aesthetic effect.

codice code	sigla part number	descrizione description	simbolo symbol
08.323.4N	PED 504 MA	Pedale 5/2 tubo ø4 - monostabile con protezione <i>Mono-stable pedal valve 5/2, push-in fittings ø4, with protection cover</i>	
08.324.4N	PED 504 BA	Pedale 5/2 tubo ø4 - bistabile con protezione <i>Bi-stable pedal valve 5/2, push-in fittings ø4, with protection cover</i>	
08.325.4N	PED 504 SA	Pedale 5/2 tubo ø4 - monostabile con protezione e fermo di sicurezza* <i>Mono-stable pedal valve 5/2, push-in fittings ø4, with protection cover and safety feature*</i>	
08.326.4N	PED 504 BSA	Pedale 5/2 tubo ø4 - bistabile con protezione e fermo di sicurezza* <i>Bi-stable pedal valve 5/2, push-in fittings ø4, with protection cover and safety feature*</i>	

* **Fermo di sicurezza:** è necessario premere il pedale a fondo con l'intera superficie della scarpa, onde evitare azionamenti accidentali.
 * **Safety feature:** to avoid accidental operation the pedal must be fully depressed. Press on the pedal with the whole shoe surface.

valvole a pedale

pedal valves



PEDALE CON MICROVALVOLA 5/2, racc. autom. ø4 - valvola in posizione arretrata - senza protezione
pedal with 5/2 microvalve, push-in fittings for ø4 tube - valve in rear position - without protection cover

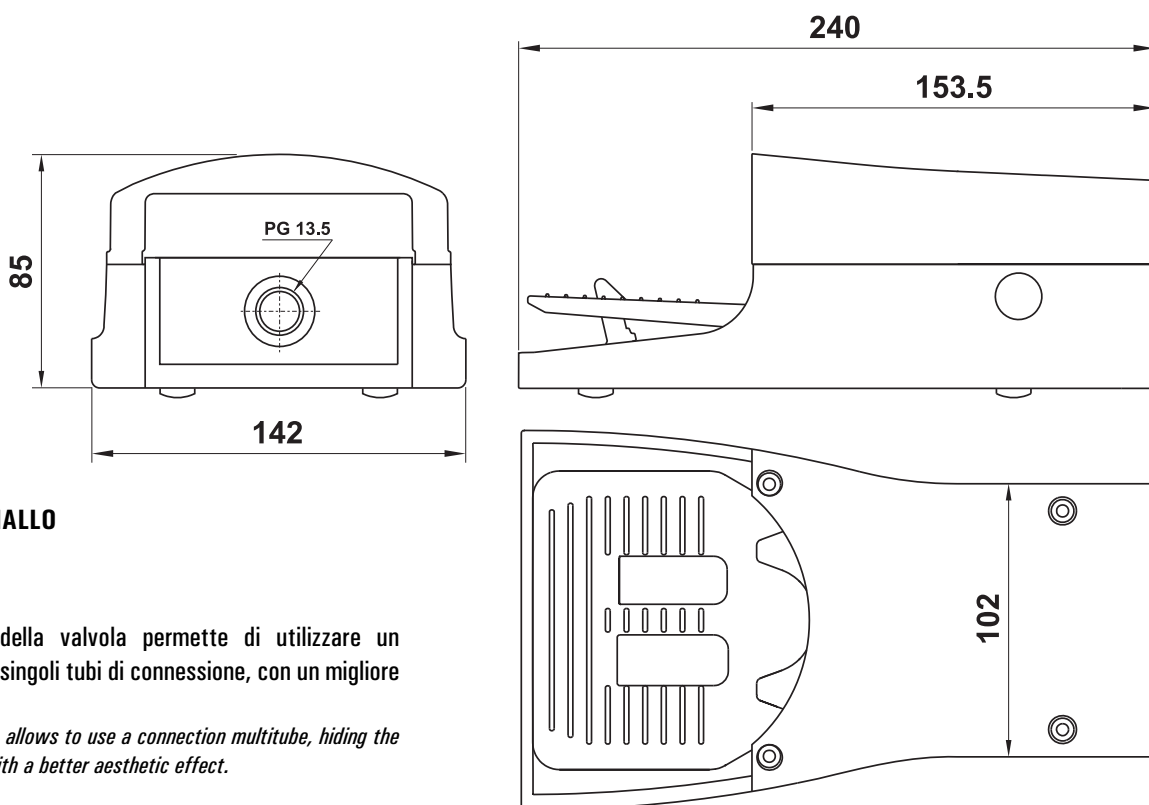

Colore della copertura: **GIALLO**
 Cover colour: **YELLOW**

La posizione arretrata della valvola permette di utilizzare un multitubo che maschera i singoli tubi di connessione, con un migliore risultato estetico.
 The rear position of the valve allows to use a connection multitube, hiding the single air connection tubes with a better aesthetic effect.

codice code	sigla part number	descrizione description	simbolo symbol
08.327.4N	PEDS 504 MA	Pedale 5/2 tubo ø4 - monostabile senza protezione <i>Mono-stable pedal valve 5/2, push-in fittings ø4, without protection cover</i>	
08.328.4N	PEDS 504 BA	Pedale 5/2 tubo ø4 - bistabile senza protezione <i>Bi-stable pedal valve 5/2, push-in fittings ø4, without protection cover</i>	
08.329.4N	PEDS 504 SA	Pedale 5/2 tubo ø4 - monostabile senza protezione, con fermo di sicurezza* <i>Mono-stable pedal valve 5/2, push-in fittings ø4, without protection cover, with safety feature*</i>	
08.330.4N	PEDS 504 BSA	Pedale 5/2 tubo ø4 - bistabile senza protezione, con fermo di sicurezza* <i>Bi-stable pedal valve 5/2, push-in fittings ø4, without protection cover, with safety feature*</i>	

* **Fermo di sicurezza:** è necessario premere il pedale a fondo con l'intera superficie della scarpa, onde evitare azionamenti accidentali.
 * **Safety feature:** to avoid accidental operation the pedal must be fully depressed. Press on the pedal with the whole shoe surface.

valvole a pedale

pedal valves



PEDALE CON VALVOLA A SPOLA 5/2 G1/4" SERVOPILOTATA E PULSANTE DI RIARMO

pedal with 5/2 G1/4" servo-piloted spool valve and reset button



Colore della copertura: **GIALLO**
Cover colour: **YELLOW**

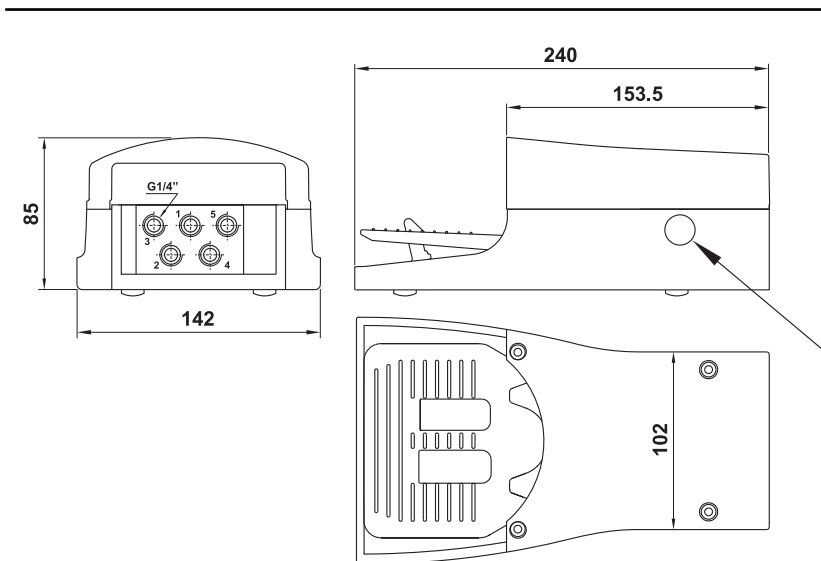
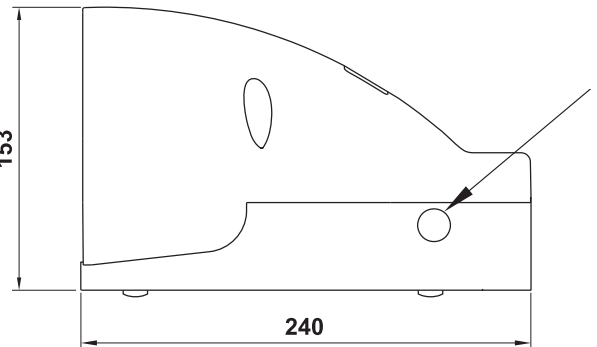
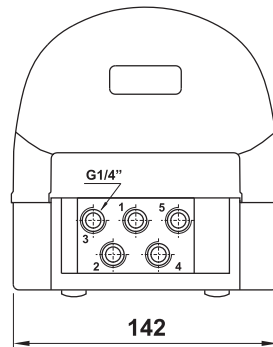

Pulsante di riarmo: dopo aver collegato l'aria di alimentazione, per attivare la valvola è necessario premere sul pulsante, altrimenti la valvola non funziona. La stessa operazione è necessaria per far ripartire la valvola dopo un'eventuale mancanza o interruzione dell'aria di alimentazione.

Reset button: after connecting air supply, to activate the valve it is necessary to push the button, otherwise the pedal valve does not function. The same operation is necessary to re-start the valve if air supply was interrupted or missing.

codice code	sigla part number	descrizione description	simbolo symbol
01.125.4N	PED 502 SR	Pedale 5/2 1/4" monostabile con protezione, con fermo di sicurezza* e pulsante di riarmo <i>Mono-stable pedal valve 5/2 1/4" with protection cover, safety feature* and reset button</i>	
01.147.4N	PEDS 502 SR	Pedale 5/2 1/4" monostabile senza protezione, con fermo di sicurezza* e pulsante di riarmo <i>Mono-stable pedal valve 5/2 1/4" without protection cover, with safety feature* and with reset button</i>	

* **Fermo di sicurezza:** è necessario premere il pedale a fondo con l'intera superficie della scarpa, onde evitare azionamenti accidentali.

* **Safety feature:** to avoid accidental operation the pedal must be fully depressed. Press on the pedal with the whole shoe surface.

valvole a pedale

pedal valves



PEDALE CON VALVOLA AD AZIONAMENTO DIRETTO A PORTATA PROGRESSIVA

pedal with directly actuated valve with progressive flow rate



Colore della copertura: **GIALLO**
Cover colour: **YELLOW**

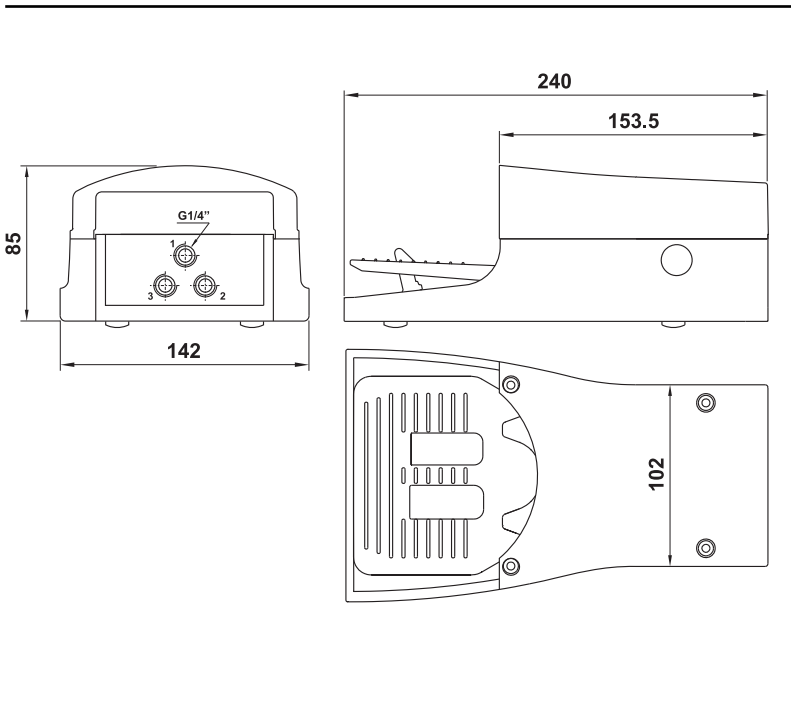
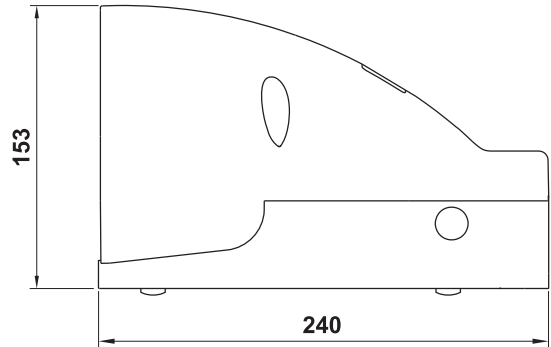
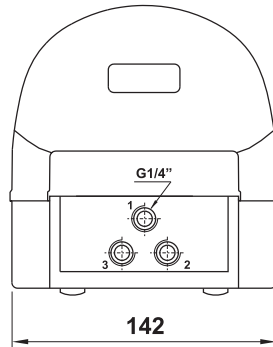

Portata della valvola in funzione della corsa del pedale
Valve flow rate related to pedal stroke

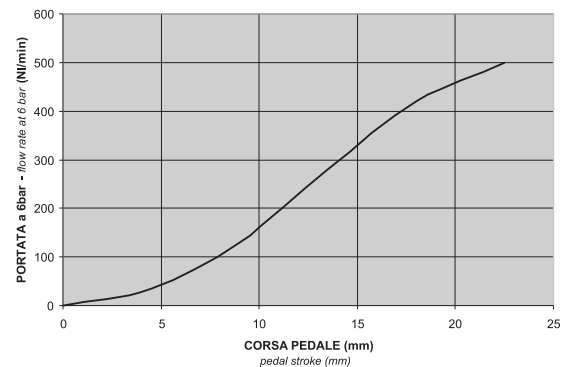

codice code	sigla part number	descrizione description	simbolo symbol
01.133.4N	PED 302 P	Pedale 3/2 NC 1/4" monostabile portata progressiva, con protezione Mono-stable pedal valve 3/2 NC 1/4" progressive flow rate, with protection cover	
01.156.4N	PEDS 302 P	Pedale 3/2 NC 1/4" monostabile portata progressiva, senza protezione Mono-stable pedal valve 3/2 NC 1/4" progressive flow rate, without protection cover	

Attenzione: la valvola non può essere utilizzata come normalmente aperta.

Attention: the valve cannot be used as normally open.

valvole a pedale

pedal valves



PEDALE DOPPIO

double pedal



I due pedali sono connessi con apposito blocco di congiunzione in alluminio. L'asta metallica di impugnatura per il sollevamento e lo spostamento (non è un'antenna) è in acciaio cromato $\varnothing 10$, altezza mm 700

The two pedals are connected by a connecting block (aluminium). The material of the hand grip metal stick (it is not an antenna) is hard chromed steel $\varnothing 10$, height mm 700

codice code	sigla part number	descrizione description
01.157.4N	PED 502 M + PEDS EB	Pedale 5/2 1/4" monostabile con protezione + pedale contatto elettrico NC-NA, bistabile senza protezione Mono-stable pedal valve 5/2 1/4" with protection cover + bi-stable pedal with electric contact NC-NO, without protection cover

Altre combinazioni sono possibili previo accordo con l'ufficio commerciale.

Other combinations are possible upon agreement with the commercial office.

ACCESSORI PER MONTAGGIO PEDALE DOPPIO

accessories for assembling of double pedal

Acquistando il blocco di congiunzione e l'asta è possibile realizzare autonomamente qualsiasi combinazione di pedali.

Buying the connecting block and the stick it is possible to make any combination of pedals.

kit blocco di congiunzione

kit connecting block

01.081.2



asta $\varnothing 10$ con pomolo; altezza mm 700

stick $\varnothing 10$; height mm 700

01.080.2

